



sModule Technology Co., Limited

Sampe Approval Drawing

Please feel free to contact us in the following ways, we must reply you within 24 hours!

Sales Email: market@smodule.com

Support Email: support@smodule.com

Contents

1.General Description	2
2. The range of applying	2
3. Features	2
4. Electrical Characteristics	3
5. The main performance of product	3
6. DC/RF characteristics	4
7.The block diagram of product principle	5
8.The supported platform	5
9.The definition of product Pin.....	5
10.The Structure and Size of product	6
11:The 6 th Pin connect to antenna, please refer to design demand	7
12:ProductDiagram.....	8
13.Tpical Solder Reflow Profile	9
14.Packing.....	10

1. General Description

sWiFiR7601MU2 product Accord with FCC CE is a highly integrated Wi-Fi single chip which supports 150 Mbps PHY rate. It fully complies with IEEE802.11n and IEEE802.11b/g stands, offering feature-rich wireless connectivity at high standards, and delivering reliable, cost-effective throughput from an extended distance.

Optimized RF architecture and baseband algorithms provide superb performance and lower power consumption. Intelligent MAC design deploys a high efficient DMA engine and hardware data processing accelerators which offloads the host processor.

BL-R7601MU2 is designed to support standard based features in the areas of security quality of service and international regulations, giving end users the greatest performance anytime and in any circumstance.

2. The range of applying

Desk-Top Pc ;Note-book ;TV; Blue-ray Disk; Tablet Pc; Set-top box

3. Features

Feature	Implementation
Power supply	VCC_3.3V +-0.2V
Clock source	40MHz
Temperature range	Work temperature: -20°C---70°C Storage temperature -55°C ~ +125°C
Package	SMT 6 pins
<ul style="list-style-type: none"> ■ IEEE 802.11b/g/n client ■ Embedded high-performance 32-bit RISC microprocessor ■ Highly integrated RF with 55nm COMS technology ■ 1T1R mode with support of 150Mbps PHY rate ■ Integrate high efficiency switching regulator ■ Best-in-class power consumption performance ■ 1/2/3/4-wire PTA Wi-Fi/Bluetooth coexistence support ■ IEEE 802.11d/h/k compliant ■ Security support for WFA WPA/WPA2 personal, WPS2.0 ,WAPI ■ Support 802.11w protected managed frames ■ QOS support of WFA,WMM,WMM PS ■ Support Wi-Fi Direct ■ Fully compliance with USB v2.0 High-Speed mode ■ Per packet transmit power control ■ Antenna diversity 	

■ Auto-calibration

4. Electrical Characteristics

Symbol	Rating	MIN	TYP	MAX	Unit
VDD33	3.3V Supply Voltage	2.97	3.3	3.63	V
VDD12	1.2V Supply Voltage	1.14	1.2	1.26	V
VDD15	1.5V Supply Voltage	1.425	1.5	1.575	V
T _{AMBIENT}	Ambient Temperature	-10	-	70	°C

Recommended operating range

Symbol	Parameter	Conditions	MIN	MAX	Unit
V _{IL}	Input Low Voltage	LVTTTL	-0.28	0.6	V
V _{IH}	Input High Voltage		2.0	3.63	V
V _{T-}	Schmitt Trigger Negative Going Threshold Voltage	LVTTTL	0.68	1.36	V
V _{T+}	Schmitt Trigger Positive Going Threshold Voltage		1.36	1.7	V
V _{OL}	Output Low Voltage	I _{OL} = 1.6~14 mA	-0.28	0.4	V
V _{OH}	Output High Voltage	I _{OH} = 1.6~14 mA	2.4	VDD33+0.33	V
R _{PU}	Input Pull-Up Resistance	PU=high, PD=low	40	190	KΩ
R _{PD}	Input Pull-Down Resistance	PU=low, PD=high	40	190	KΩ

DC Characteristics

5. The main performance of product

Item	Description
The supported protocol and standard	IEEE 802.11n, IEEE 802.11g, IEEE 802.11b
Interface type	USB2.0
The range of frequency	2.4-2.484GHZ
The amount of working Channel	1-11 (America, Canada) ;1-13 (China, Europe) ;1-14 (Japan)
Data Modulation	OFDM/DBPSK/DQPSK/CCK
Working Mode	Infrastructure, Ad-Hoc
The transmitting rate	135/54/48/36/24/18/12/9/6 /1M (self-adapting)
Spread spectrum	DSSS
Sensitivity @PER	135M: < -65dBm@10%PER, 65M: < -68dBm@10%PER, 54M: < -70dBm@10%PER, 11M: < -84dBm@8%PER ,
RF Power & EVM	135M: 14±2DBM, EVM<-28 dB; 65M: 14±2DBM, EVM<-28 dB; 54M: 15±2DBM, EVM<-28 dB;



	11M: 17±2DBM , EVM<-23 dB;
Throughput	90Mbps(external 2dbi antenna ,damping 40dbm in Shielding box)
The connect type of Antenna	Connect to the external antenna through the half hole
LED indicator	status indicator
The transmit distance	Indoor 100M, Outdoor 300M, according the local environment
Working Power consumption	455MW
MENS(L*W*H)	12.3MM*13MM*1.6MM
The chipset model	MT7601U

6. DC/RF characteristics

Terms	Contents			
Specification : IEEE802.11b				
Mode	DSSS / CCK			
Frequency	2412 – 2484MHz			
Data rate	1, 2, 5.5, 11Mbps			
DC Characteristics	min	Typ.	max.	unit
TX mode	239	245	249	mA
Rx mode	91	92	93	mA
standby mode	47	48	48	mA
Specification : IEEE802.11g				
Mode	OFDM			
Frequency	2412 - 2484MHz			
Data rate	6, 9, 12, 18, 24, 36, 48, 54Mbps			
DC Characteristics	min	Typ.	max.	unit
TX mode	149	150	153	mA
Rx mode	92	93	100	mA
standby mode	46	48	49	mA
Specification : IEEE802.11n				
Mode	OFDM			
Frequency	2412 - 2484MHz			
Data rate	6.5, 13, 19.5, 26, 39, 52, 58.5, 65Mbps			
DC Characteristics	min	Typ.	max.	unit
TX mode	151	152	153	mA
Rx mode	91	92	93	mA
standby mode	47	48	49	mA

7.The block diagram of product principle

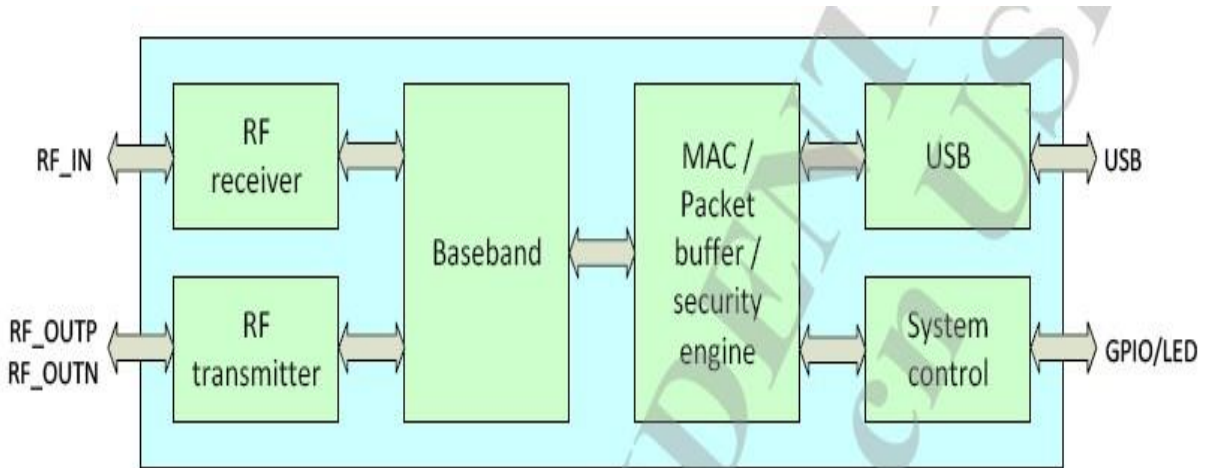
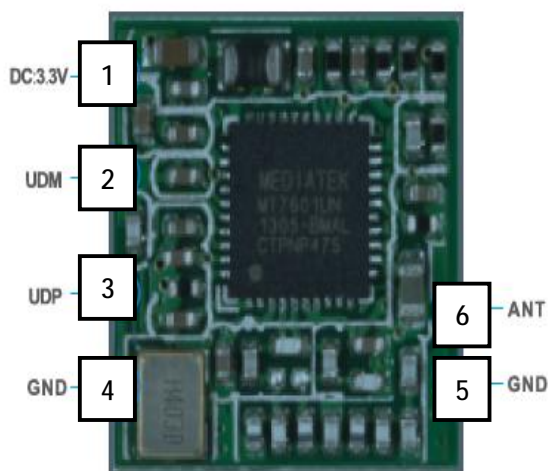

Figure 1 MT7601 block diagram

8. The supported platform

Operating System	CPU Framework	Driver
WIN2000/XP/VISTA/WIN7	X86 Platform	Enable
LINUX2.4/2.6	ARM, MIPSII	Enable
WINCE5.0/6.0	ARM ,MIPSII	Enable

9.The definition of product Pin



the front side



the back side

Top and bottom view of -R7601MU2 Ver3.0

Pin No:	TYPE	Description
1	P	DC :3.3V
2	I/O	UDM-
3	I/O	UDP+
4	P	GND
5	P	GND
6	O	ANT

10.The Structure and Size of product (Tolerance : +/-0.2mm)

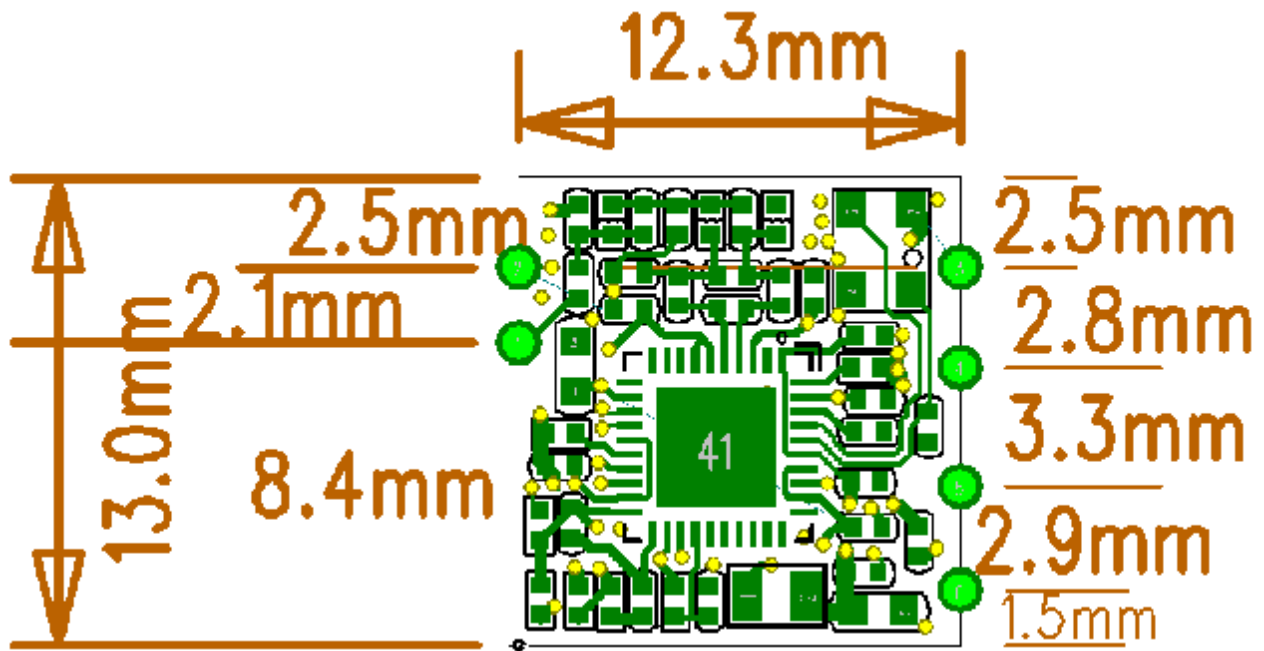

11: The 6th Pin connect to antenna, please refer to design demand

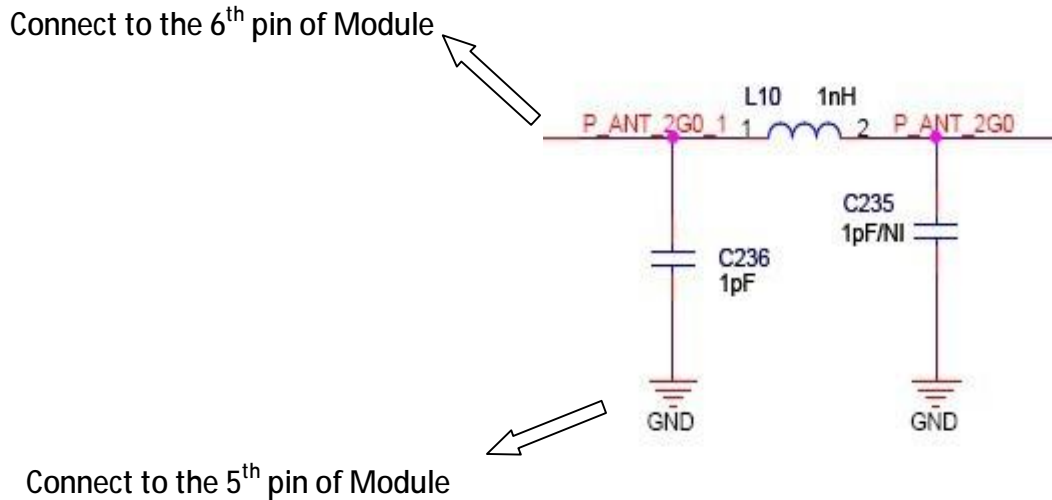

- The current of 3.3V power supply must be >300mA, its ripple wave must be <30mV. The GND pins of module and external antenna need to be an incorporated part. The ground plane should be larger, module and antenna should keep far away from interference source.
- The sixth pin is 2.4G high frequency output, coplanar impedance of layout line between this pin to antenna interface should be $50\ \Omega$, we suggest use arc line or straight line, and beside the line there will be ground plane that its length as shout as possible, the longest length is no more than 50mm.
- L10, C235, C236 constitute a π -type network that we preset, please make it close to antenna interface, this π -type network is used to match the antenna parameters and control the radiation. It should be adjusted according to the real condition when being used. Normally you can only mount L1 that its parameters are: 1NH. No need C235 .

12. Product Diagram

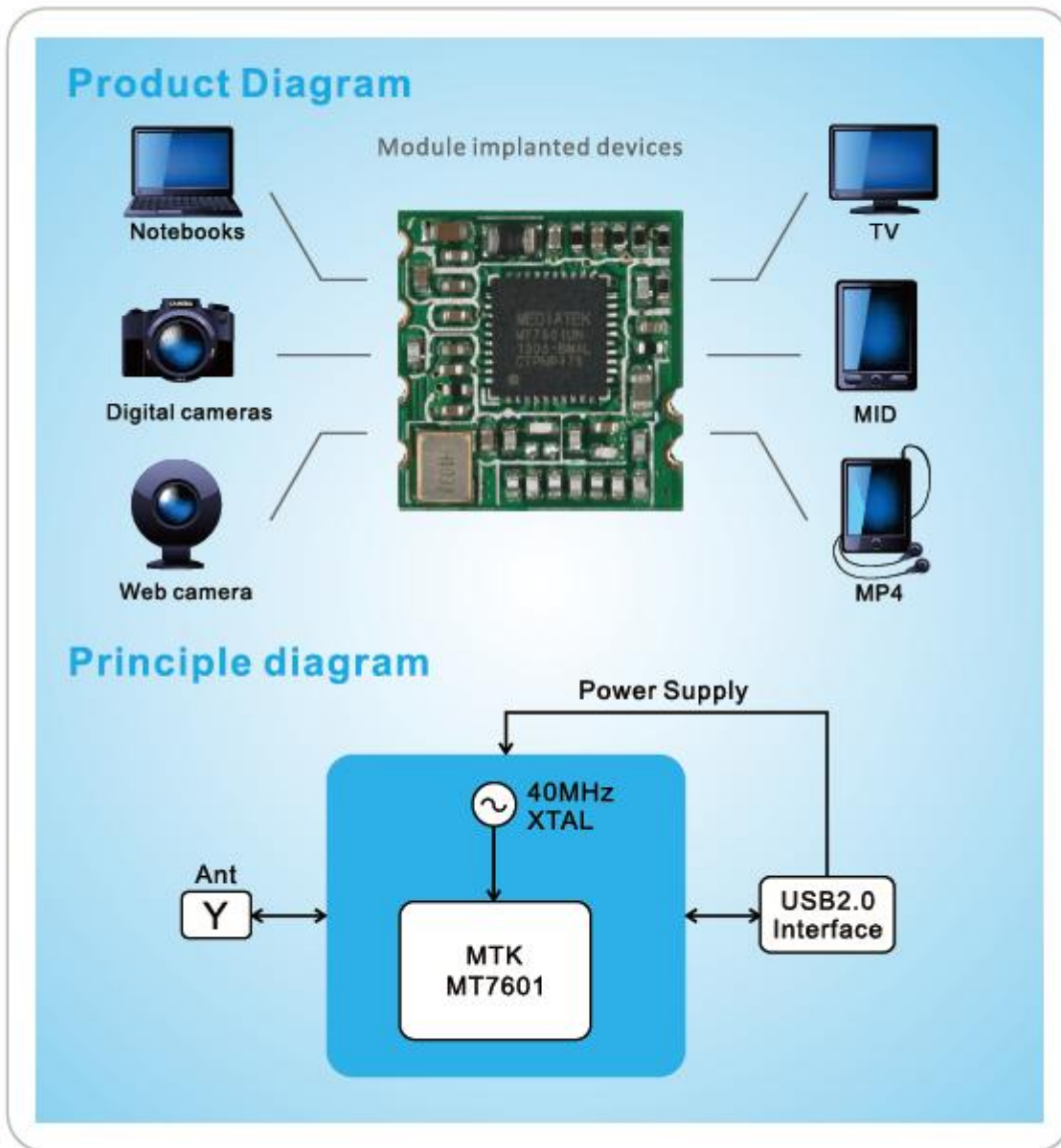

13. Typical Solder Reflow Profile

Referred to IPC-A-610E-2010/JEDEC standard: Peak Temperature : $\leq 260^{\circ}\text{C}$, 10sec. Max.
 Number of Times : ≤ 2 times

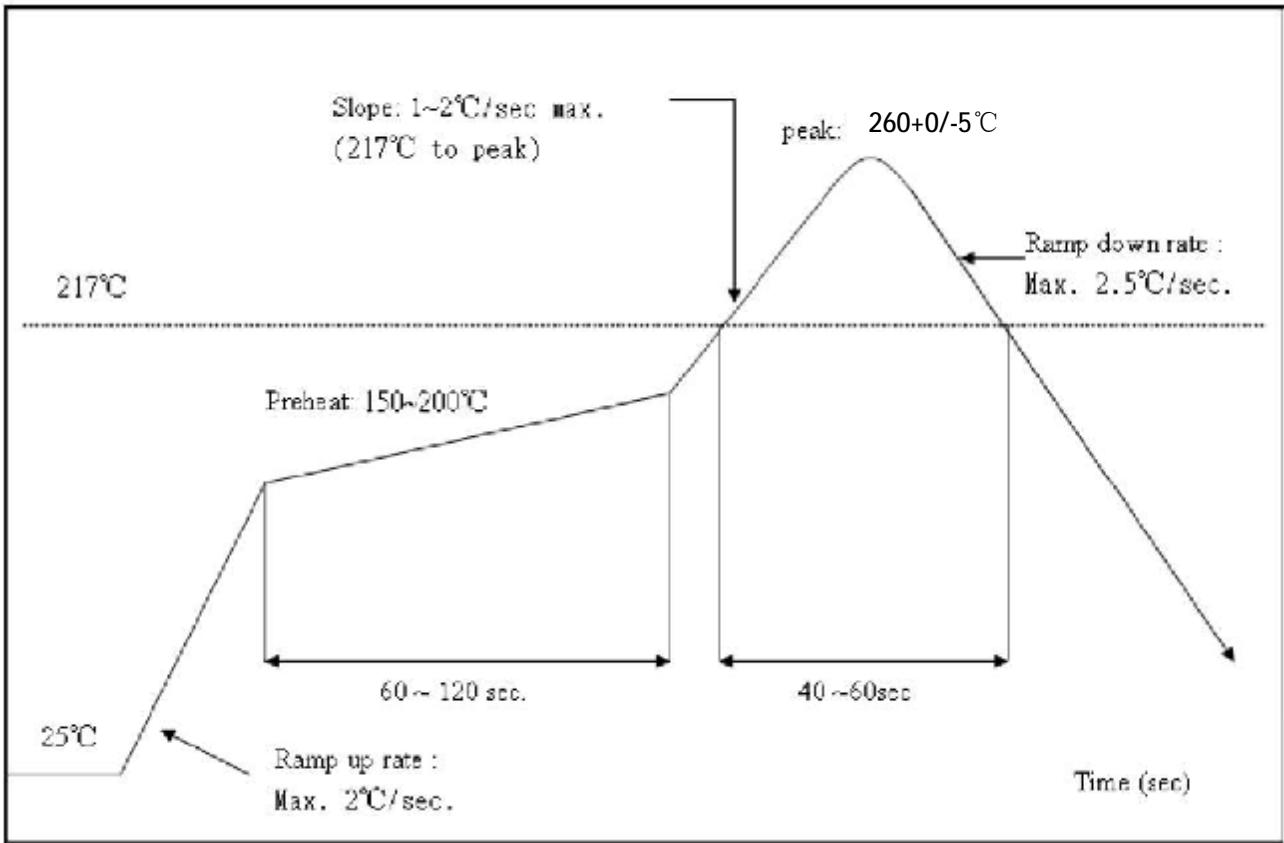

不

不

14:Packing

