



ON Semiconductor®

<http://onsemi.com>

LV8548MC

Monolithic Linear IC

12V Low Saturation Voltage Drive Forward/Reverse Motor Driver

Overview

The LV8548MC is a 2-channel low saturation voltage forward/reverse motor driver IC. It is optimal for motor drive in 12V system products and can drive either two DC motors, one DC motor using parallel connection, or it can drive a stepper motor in Full-step and Half-step.

Function

- DMOS output transistor adoption (Upper and lower total $R_{ON}=1\Omega$ typ)
- For one power supply (The control system power supply is unnecessary.)
- Our motor driver IC, LB1948MC, and compatible pin
- It is possible to connect it in parallel (parallel, connected operation of drive ch).
- The compact package (SOIC10) is adopted.
- $V_{CC\ max}=20v$, $I_O\ max=1A$
- Current consumption 0 when standing by
- Built-in brake function

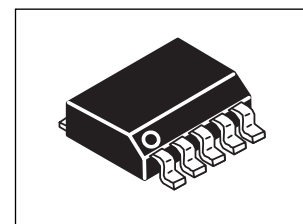

SOIC10

Specifications

Absolute Maximum Ratings at $T_a = 25^\circ C$

Parameter	Symbol	Conditions	Ratings	Unit
Maximum power supply voltage	$V_{CC\ max}$	VCC	-0.3 to +20	V
Output impression voltage	VOUT	OUT1 , OUT2 , OUT3 , OUT4	-0.3 to +20	V
Input impression voltage	V_{IN}	IN1 , IN2 , IN3 , IN4	-0.3 to +6	V
GND pin outflow current	IGND	Per ch	1.0	A
Allowable Power dissipation	$P_d\ max$	*	1.0	W
Operating temperature	T_{opr}		-30 to +85	$^\circ C$
Storage temperature	T_{stg}		-40 to +150	$^\circ C$

*: When mounted on the specified printed circuit board (57.0mm × 57.0mm × 1.6mm), glass epoxy, both sides

Caution 1) Absolute maximum ratings represent the value which cannot be exceeded for any length of time.

Caution 2) Even when the device is used within the range of absolute maximum ratings, as a result of continuous usage under high temperature, high current, high voltage, or drastic temperature change, the reliability of the IC may be degraded. Please contact us for the further details.

Stresses exceeding Maximum Ratings may damage the device. Maximum Ratings are stress ratings only. Functional operation above the Recommended Operating Conditions is not implied. Extended exposure to stresses above the Recommended Operating Conditions may affect device reliability.

Recommendation Operating Conditions at $T_a = 25^\circ C$

Parameter	Symbol	Conditions	Ratings	Unit
Power supply voltage	V_{CC}	VCC	4.0 to 16	V
Input "H" level voltage	V_{INH}	IN1 , IN2 , IN3 , IN4	+1.8 to +5.5	V
Input "L" level voltage	V_{INL}		-0.3 to +0.7	V

ORDERING INFORMATION

See detailed ordering and shipping information on page 11 of this data sheet.

LV8548MC

Electrical Characteristics at Ta = 25°C, VCC = 12V

Parameter	Symbol	Conditions	Ratings			Unit
			min	typ	max	
Power supply voltage	I _{CC0}	Standby mode IN1=IN2=IN3=IN4="LOW"			1	μA
	I _{CC1}	It is "High" from IN1 as for either of IN4. Load opening		1.7	2.3	mA
Input current	I _{IN}	V _{IN} =5V	35	50	65	μA
Thermal shutdown operating temperature	T _{tsd}	Design certification	150	180	210	°C
Width of temperature hysteresis	ΔT _{tsd}	Design certification		40		°C
Low voltage protection function operation voltage	V _{thVCC}		3.3	3.5	3.65	V
Release voltage	V _{thret}		3.55	3.8	3.95	V
Output ON resistance (Upper and lower total)	R _{ON}	I _{OUT} =1.0A	0.7	1	1.25	Ω
Output leak current	I _{Oleak}	V _O =16V			10	μA
Diode forward voltage	V _D	I _D =1.0A		1.0	1.2	V

Package Dimensions

SOIC-10NB
CASE 751BQ-01
ISSUE A

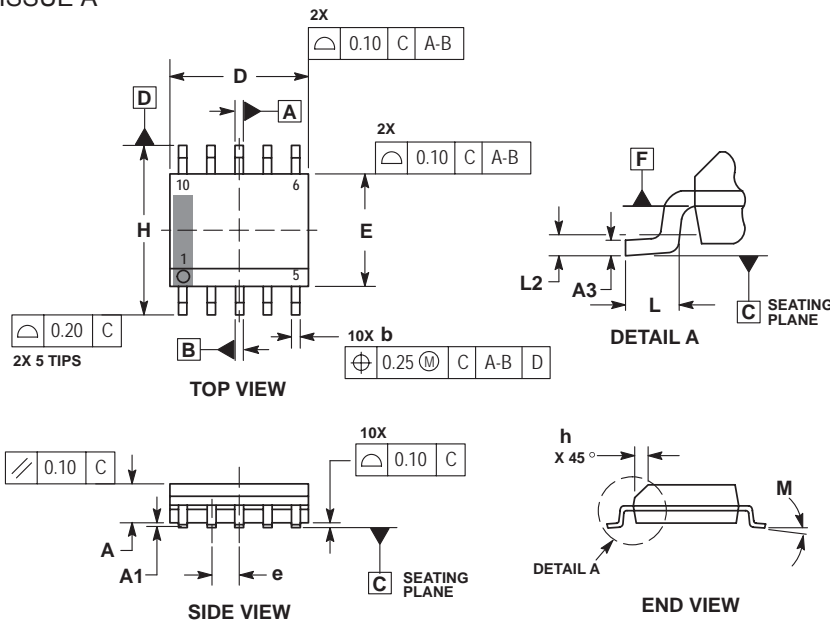

NOTES:

1. DIMENSIONING AND TOLERANCING PER ASME Y14.5M, 1994.
2. CONTROLLING DIMENSION: MILLIMETERS.
3. DIMENSION b DOES NOT INCLUDE DAMBAR PROTRUSION. ALLOWABLE PROTRUSION SHALL BE 0.10mm TOTAL IN EXCESS OF 'b' AT MAXIMUM MATERIAL CONDITION.
4. DIMENSIONS D AND E DO NOT INCLUDE MOLD FLASH, PROTRUSIONS, OR GATE BURRS. MOLD FLASH, PROTRUSIONS, OR GATE BURRS SHALL NOT EXCEED 0.15mm PER SIDE. DIMENSIONS D AND E ARE DETERMINED AT DATUM F.
5. DIMENSIONS A AND B ARE TO BE DETERMINED AT DATUM F.
6. A1 IS DEFINED AS THE VERTICAL DISTANCE FROM THE SEATING PLANE TO THE LOWEST POINT ON THE PACKAGE BODY.

DIM	MILLIMETERS	
	MIN	MAX
A	1.25	1.75
A1	0.10	0.25
A3	0.17	0.25
b	0.31	0.51
D	4.80	5.00
E	3.80	4.00
e	1.00 BSC	
H	5.80	6.20
h	0.37 REF	
L	0.40	1.27
L2	0.25 BSC	
M	0°	8°

GENERIC MARKING DIAGRAM*

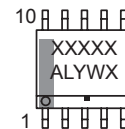

- XXXXXX = Specific Device Code
- A = Assembly Location
- L = Wafer Lot
- Y = Year
- W = Work Week
- = Pb-Free Package

*This information is generic. Please refer to device data sheet for actual part marking. Pb-Free indicator, "G", may or not be present.

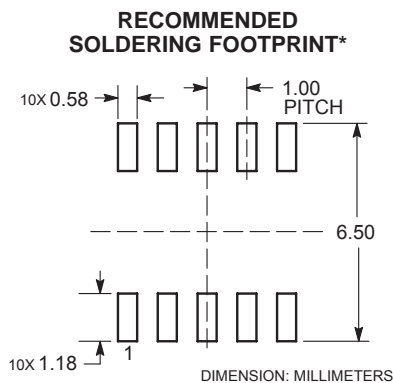

*For additional information on our Pb-Free strategy and soldering details, please download the ON Semiconductor Soldering and Mounting Techniques Reference Manual, SOLDERRM/D.

Block Diagram

1. At two DC motor drive

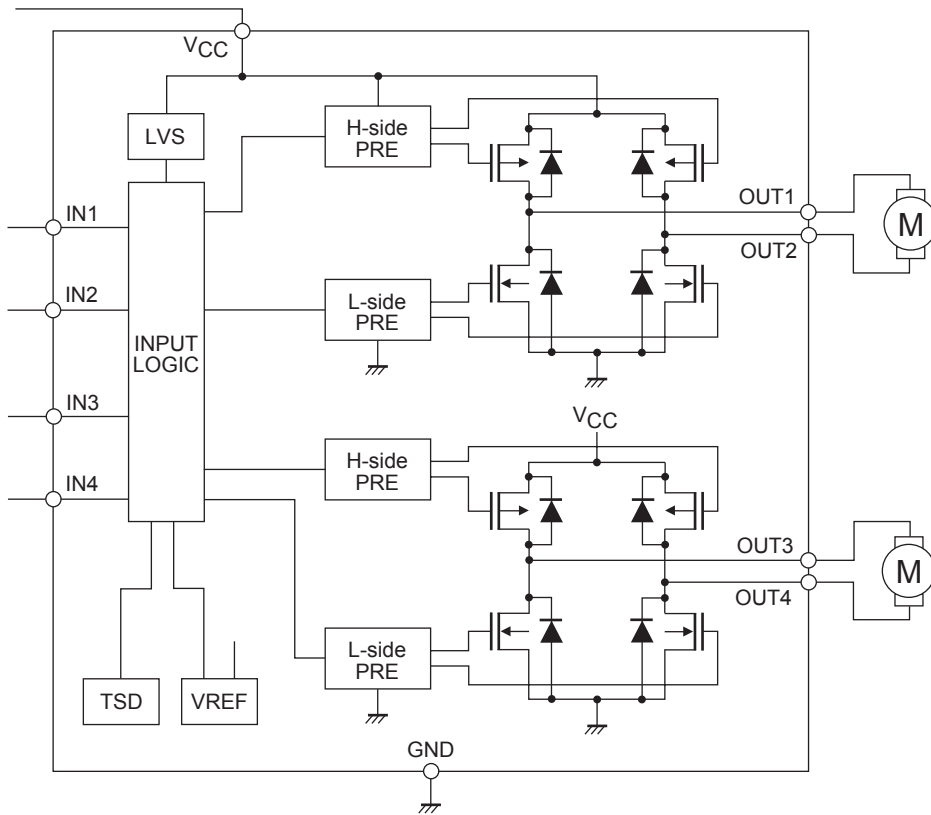

2. At one stepper motor drive

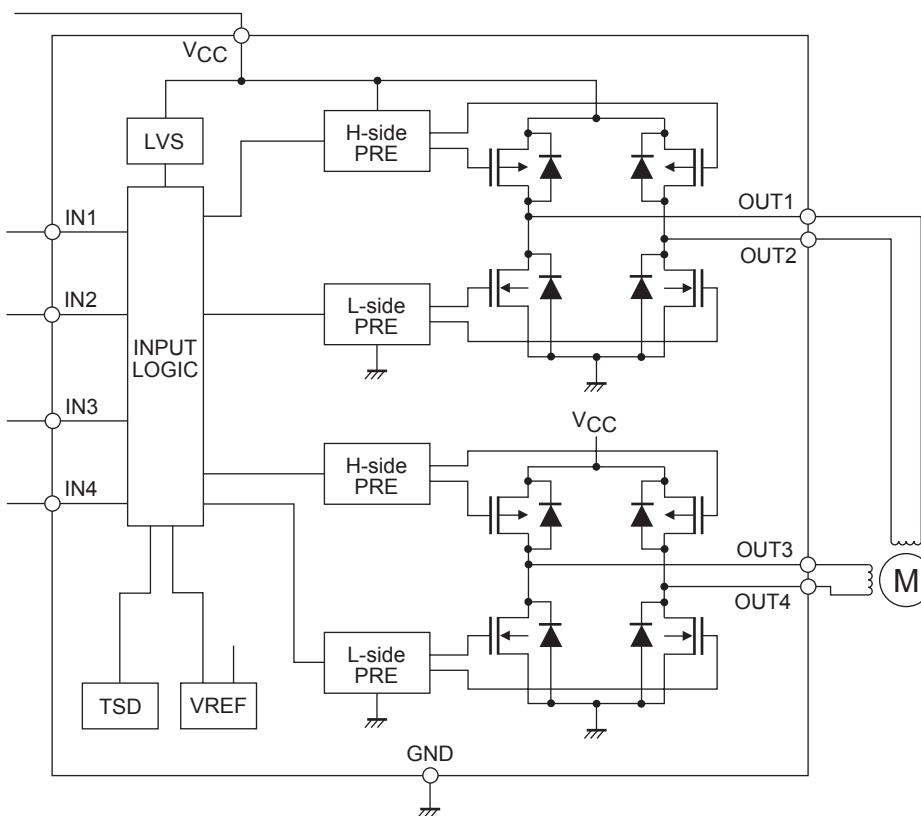

LV8548MC

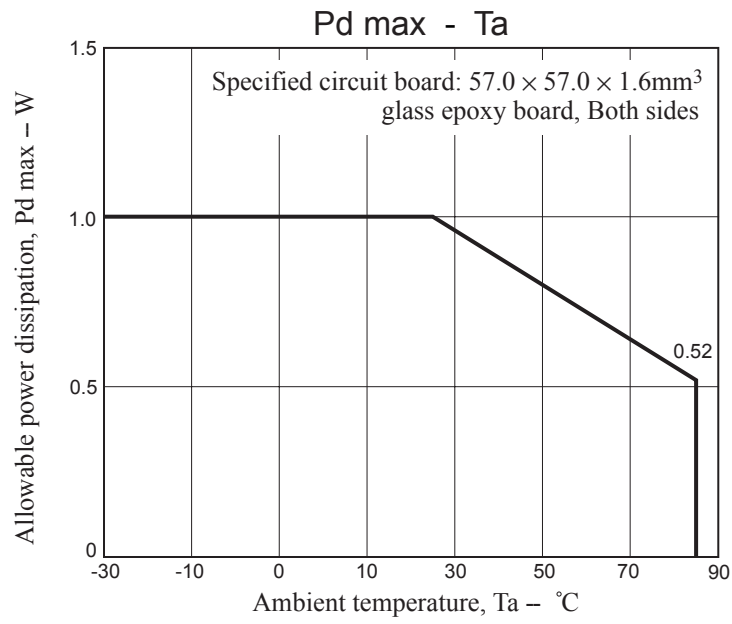

Pin Assignment

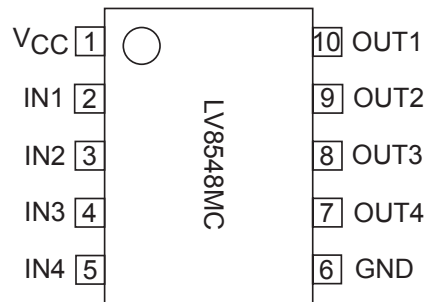

LV8548MC

Pin function

Pin No.	Pin name	Pin function	Equivalent Circuit
1	V _{CC}	Power-supply voltage pin. V _{CC} voltage is impressed. The permissible operation voltage is from 4.0 to 16.0(V). The capacitor is connected for stabilization for GND pin (6pin).	
2	IN1	Motor drive control input pin. Driving control input pin of OUT1 (10pin) and OUT2 (9pin). It combines with IN2 pin (3pin) and it fights desperately. The digital input it, range of the "L" level input is 0 to 0.7(V), range of the "H" level input is from 1.8 to 5.5(V). PWM can be input. Pull-down resistance 100(kΩ) is built into in the pin. It becomes a standby mode because all IN1, IN2, IN3, and IN4 pins are made "L", and the circuit current can be adjusted to 0.	
3	IN2	Motor drive control input pin. Driving control input pin of OUT1 (10pin) and OUT2 (9pin). It combines with IN1 pin (2pin) and it uses it. PWM can be input. With built-in pull-down resistance.	
4	IN3	Motor drive control input pin. Driving control input pin of OUT3 (8pin) and OUT4 (7pin). It combines with IN4 pin (5pin) and it uses it. PWM can be input. With built-in pull-down resistance.	
5	IN4	Motor drive control input pin. Driving control input pin of OUT3 (8pin) and OUT4 (7pin). It combines with IN3 pin (4pin) and it uses it. PWM can be input. With built-in pull-down resistance.	
6	GND	Ground pin.	
7	OUT4	Driving output pin. The motor coil is connected between terminal OUT3 (8pin).	
8	OUT3	Driving output pin. The motor coil is connected between terminal OUT4 (7pin).	
9	OUT2	Driving output pin. The motor coil is connected between terminal OUT1 (10pin).	
10	OUT1	Driving output pin. The motor coil is connected between terminal OUT2 (9pin).	

Operation explanation

1. DCM output control logic

Input				Output				Remarks
IN1	IN2	IN3	IN4	OUT1	OUT2	OUT3	OUT4	
L	L	L	L	OFF	OFF	OFF	OFF	Stand-by
L	L			OFF	OFF			Stand-by
H	L			H	L			Forward
L	H			L	H			Reverse
H	H			L	L			Brake
		L	L			OFF	OFF	Stand-by
		H	L			H	L	Forward
		L	H			L	H	Reverse
		H	H			L	L	Brake

LV8548MC

2. About the switch time from the stand-by state to the state of operation

When IN1, IN2, IN3, IN4 are "L", this IC has completely stopped operating. After the time of reset of about 7μs of an internal setting, it shifts to a prescribed output status corresponding to the state of the input when the signal enters the input terminal.

Reset of about 7μs doesn't hang even if the motor is driven from the stand-by state when either CH drives and the output becomes an output status corresponding to the state of the input. As for full power TR between the reset time, turning off is maintained.

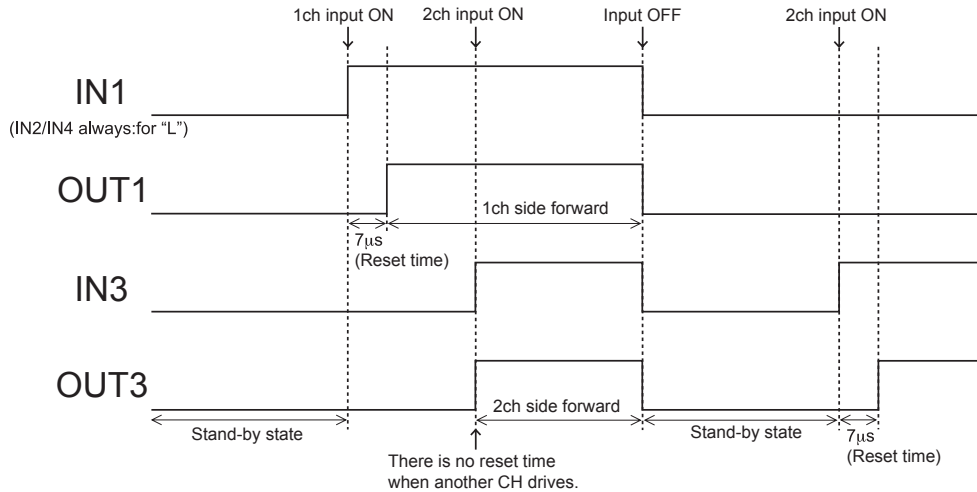

3. Example of current wave type in each excitation mode when stepper motor parallel input is controlled.

• Full-step mode

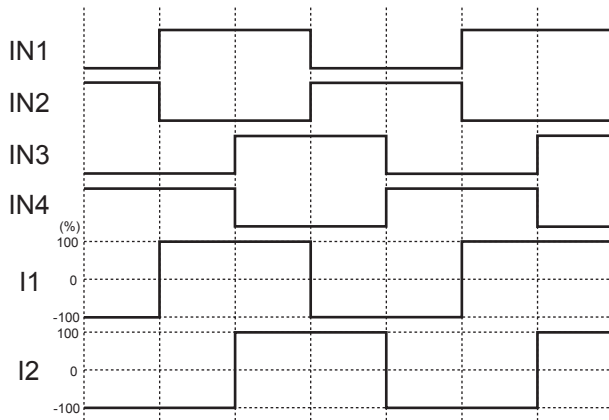

• Half-step mode

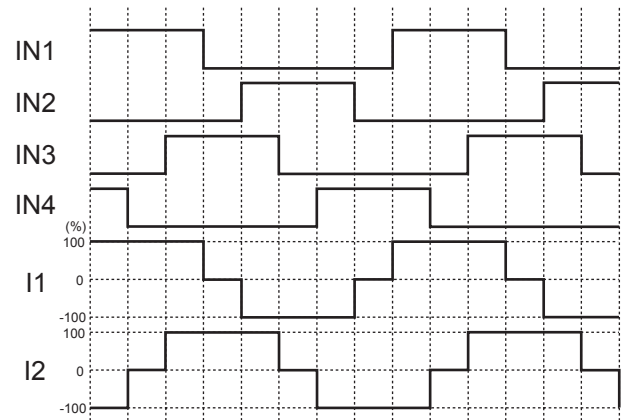

4. Thermal shutdown function

The thermal shutdown circuit is incorporated and the output is turned off when junction temperature T_j exceeds 180°C. As the temperature falls by hysteresis, the output turned on again (automatic restoration).

The thermal shutdown circuit does not guarantee the protection of the final product because it operates when the temperature exceed the junction temperature of $T_{jmax}=150^\circ\text{C}$.

$T_{SD} = 180^\circ\text{C}$ (typ)

$\Delta T_{SD} = 40^\circ\text{C}$ (typ)

Application Circuit Example

1. Example of applied circuit when two DC motor driving

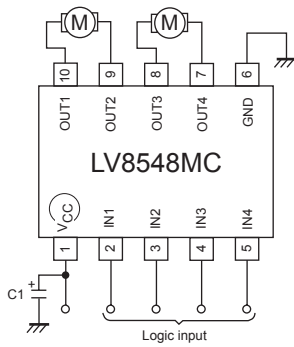

2. Example of applied circuit when one stepper motor driving

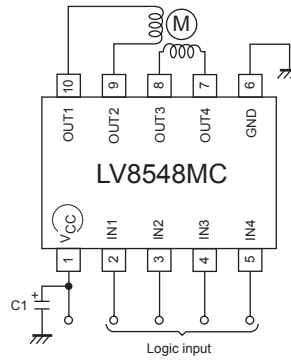

3. Example of applied circuit when connecting it in parallel

The use likened to H bridge 1ch is shown possible in the figure below by connecting IN1 with IN3, IN2 with IN4, OUT1 with OUT3, OUT2, and OUT4. ($I_O \text{ max}=2.0\text{A}$, Upper and lower total $R_{ON}=0.5\Omega$)

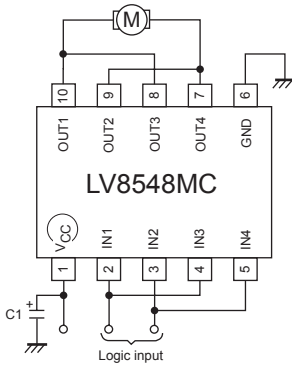

* Bypass capacitor (C1) connected between V_{CC} -GND of all examples of applied circuit recommends the electric field capacitor of $0.1\mu\text{A}$ to $10\mu\text{A}$.

Confirm there is no problem in operation in the state of the motor load including the temperature property about the value of the capacitor.

Mount the position where the capacitor is mounted on nearest IC.

Measurement connection diagram

- (1) Current consumption when standing by I_{CC0}
 Current consumption I_{CC1}

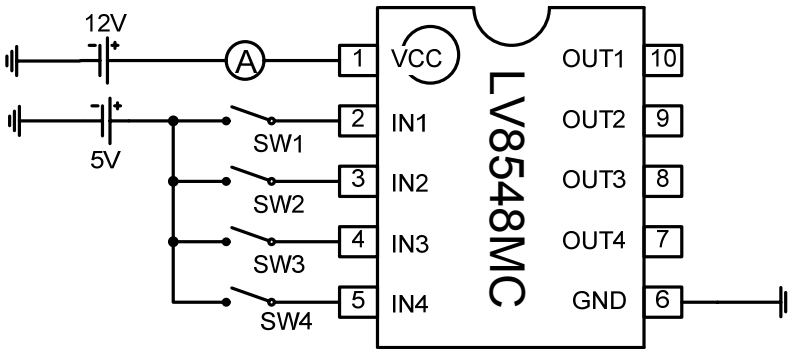

Measure I_{CC0} with all SW OFF.
 Measure I_{CC1} with any of the SW1-4 ON.

- (2) Input current I_{IN}

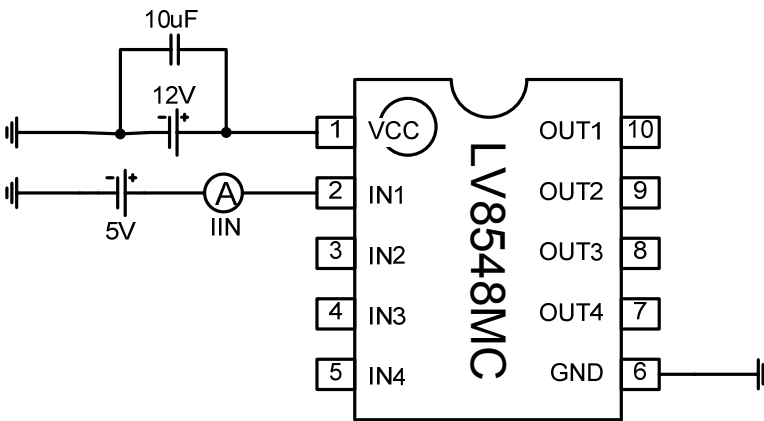

This is about the measurement of IN1 pin. Measure the other IN2-4 pins as is this case.

- (3) Input "H" level voltage V_{INH}

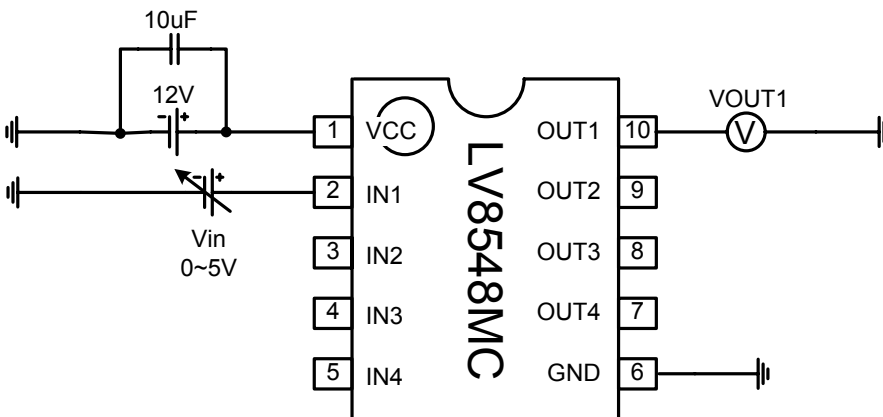

Measure the V_{in} value at the time V_{OUT1} changes to "H" while varying V_{in} 0-5V.
 This is about the measurement of IN1 pin. Measure the other IN2-4 pins as is this case.

LV8548MC

(4) Low voltage protection function operation voltage $V_{th}V_{CC}$ / Release voltage V_{thret}

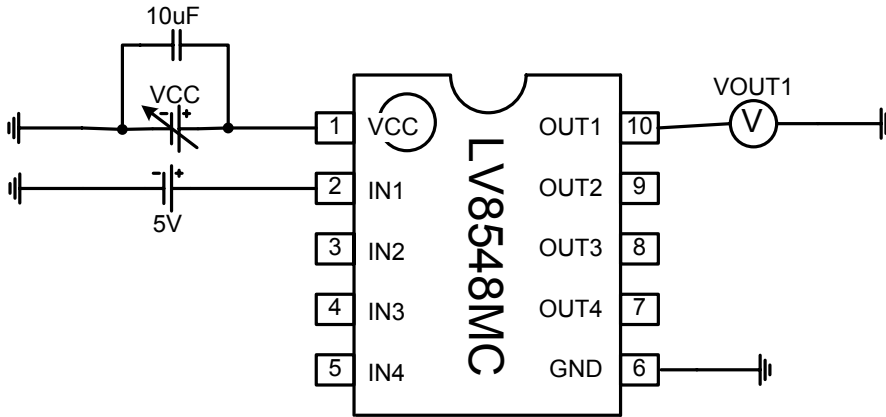

Low voltage protection function
 Operation voltage : $V_{CC}=12V$ to $0V$
 Release voltage : $V_{CC}=0V$ to $12V$

To measure the operating voltage of the reduced voltage protection, measure the V_{CC} value at the time V_{OUT1} becomes "L" while varying V_{CC} from $12V$ to $0V$.

To measure the release voltage of the reduced voltage protection, measure the V_{CC} value at the time V_{OUT1} becomes "H" while varying V_{CC} from $0V$ to $12V$.

(5) Output ON resistance R_{on}

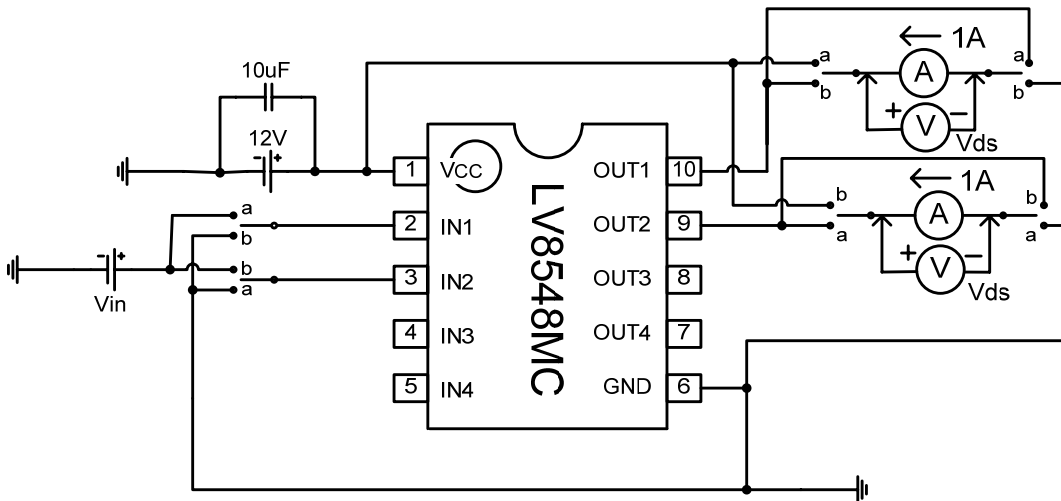

SW_a side :
 OUT1 Upper-side/OUT2 Lower-side
 OUT3 Upper-side/OUT4 Lower-side
 SW_b side :
 OUT1 Lower-side/OUT2 Upper-side
 OUT3 Lower-side/OUT4 Upper-side

Measure OUT1 upper side and OUT2 lower side FET with the SW set to "a".

Measure OUT1 lower side and OUT2 upper side FET with the SW set to "b".

Measure OUT3 and OUT4 as are the cases of OUT1 and OUT2.

LV8548MC

(6) Output leak current I_{leak}

<Each OUT Upper-side>

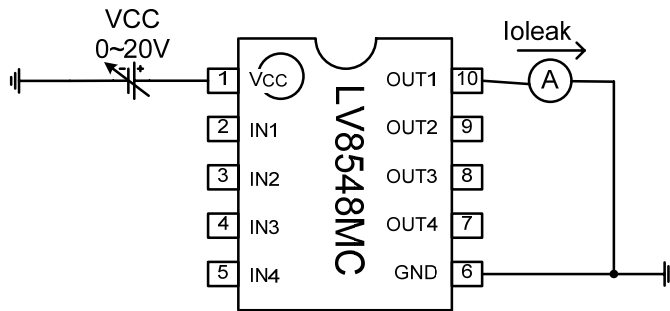

<Each OUT Lower-side>

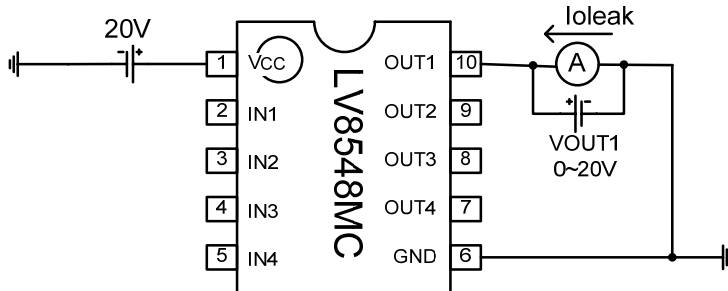

To measure the upper FET output leak current, set the OUT to 0V and measure the OUT current while varying VCC from 0 to 20V.

To measure the lower FET output leak current, set the VCC to 20V and measure the OUT current while varying OUT from 0 to 20V.

This is about the measurement of OUT1 pin. Measure the other OUT2-4 pins as is this case.

(7) Diode forward voltage V_D

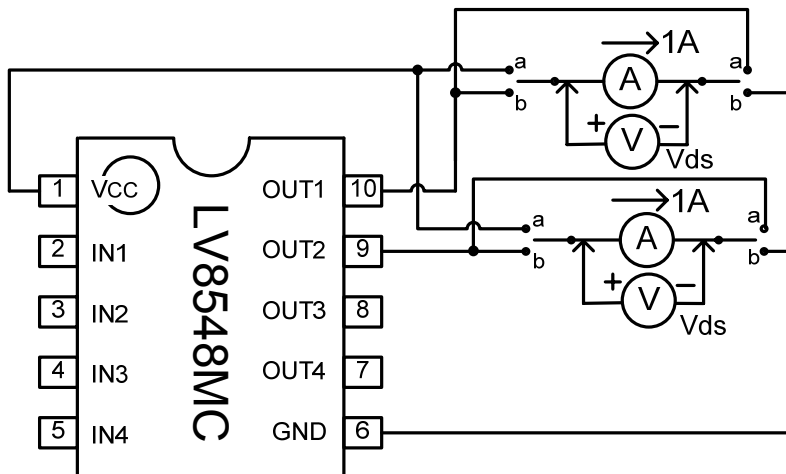

SW_a side : Each OUT Upper-side

SW_b side : Each OUT Lower-side

Measure OUT1 and OUT2 upper FET with the SW set to "a".

Measure OUT1 and OUT2 lower FET with the SW set to "b".

Measure OUT3 and OUT4 as are the cases/connections of OUT1 and OUT2.

LV8548MC

ORDERING INFORMATION

Device	Package	Shipping (Qty / Packing)
LV8548MC-AH	SOIC10 (Pb-Free / Halogen Free)	2500 / Tape & Reel
LV8548MC-BH	SOIC10 (Pb-Free / Halogen Free)	2500 / Tape & Reel
LV8548MCZ-AH	SOIC10 (Pb-Free / Halogen Free)	2500 / Tape & Reel

ON Semiconductor and the ON logo are registered trademarks of Semiconductor Components Industries, LLC (SCILLC). SCILLC owns the rights to a number of patents, trademarks, copyrights, trade secrets, and other intellectual property. A listing of SCILLC's product/patent coverage may be accessed at www.onsemi.com/site/pdf/Patent-Marking.pdf. SCILLC reserves the right to make changes without further notice to any products herein. SCILLC makes no warranty, representation or guarantee regarding the suitability of its products for any particular purpose, nor does SCILLC assume any liability arising out of the application or use of any product or circuit, and specifically disclaims any and all liability, including without limitation special, consequential or incidental damages. "Typical" parameters which may be provided in SCILLC data sheets and/or specifications can and do vary in different applications and actual performance may vary over time. All operating parameters, including "Typicals" must be validated for each customer application by customer's technical experts. SCILLC does not convey any license under its patent rights nor the rights of others. SCILLC products are not designed, intended, or authorized for use as components in systems intended for surgical implant into the body, or other applications intended to support or sustain life, or for any other application in which the failure of the SCILLC product could create a situation where personal injury or death may occur. Should Buyer purchase or use SCILLC products for any such unintended or unauthorized application, Buyer shall indemnify and hold SCILLC and its officers, employees, subsidiaries, affiliates, and distributors harmless against all claims, costs, damages, and expenses, and reasonable attorney fees arising out of, directly or indirectly, any claim of personal injury or death associated with such unintended or unauthorized use, even if such claim alleges that SCILLC was negligent regarding the design or manufacture of the part. SCILLC is an Equal Opportunity/Affirmative Action Employer. This literature is subject to all applicable copyright laws and is not for resale in any manner.

Mouser Electronics

Authorized Distributor

Click to View Pricing, Inventory, Delivery & Lifecycle Information:

[ON Semiconductor:](#)

[LV8548MC-BH](#) [LV8548MC-AH](#) [LV8548MCZ-AH](#)