

Toshiba Bi-CD Integrated Circuit Silicon Monolithic

# TB6617FNG

## H-Bridge driver IC

TB6617FNG is a H-bridge driver IC with output transistor in LDMOS structure with low ON-resister.

TB6617FNG includes selectable 4 modes, CW, CCW, short brake, and stop mode

## Features

- Supply Voltage ;  $V_M = 50\text{ V (Max.)}$
- Output Current ;  $I_{out} = 1.2\text{ A (avg)}/2\text{ A (peak)}$
- Output Low-On Resistor ;  $1.4\ \Omega$   
(Upper+Lower Typ. @ $V_{cc} = V_M = 5\text{ V}$ )
- Available for  $f_{PWM} \leq 350\text{ kHz}$
- Stand-by (Power save) function
- CW/CCW/Short Brake/Stop Function modes
- Built-in thermal shut down (TSD) circuit,  
over current detection (ISD) circuit,  $V_{cc}$  low voltage detection circuit (UVD)
- Small surface mounting package SSOP16(0.65 mm pitch)

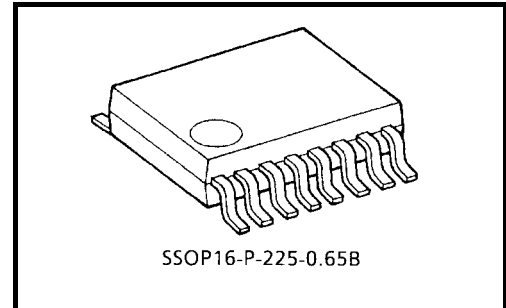

Weight: 0.07 g (typ.)

This product contains weak pins for ESD so pay attention for treating it.  
Weak pins ; 8pin and 9pin

The following conditions apply to solderability:  
About solderability, following conditions were confirmed  
(1)Use of Sn-37Pb solder Bath  
·solder bath temperature: 230°C  
·dipping time: 5 seconds  
·the number of times: once  
·use of R-type flux  
(2)Use of Sn-3.0Ag-0.5Cu solder Bath  
·solder bath temperature: 245°C  
·dipping time: 5 seconds  
·the number of times: once  
·use of R-type flux

## Block Diagram

Block or circuit in the diagram is just for explanation the function, so could be simplified in some case. Also the diagram does not mean the agreement for the license of industry ownership right

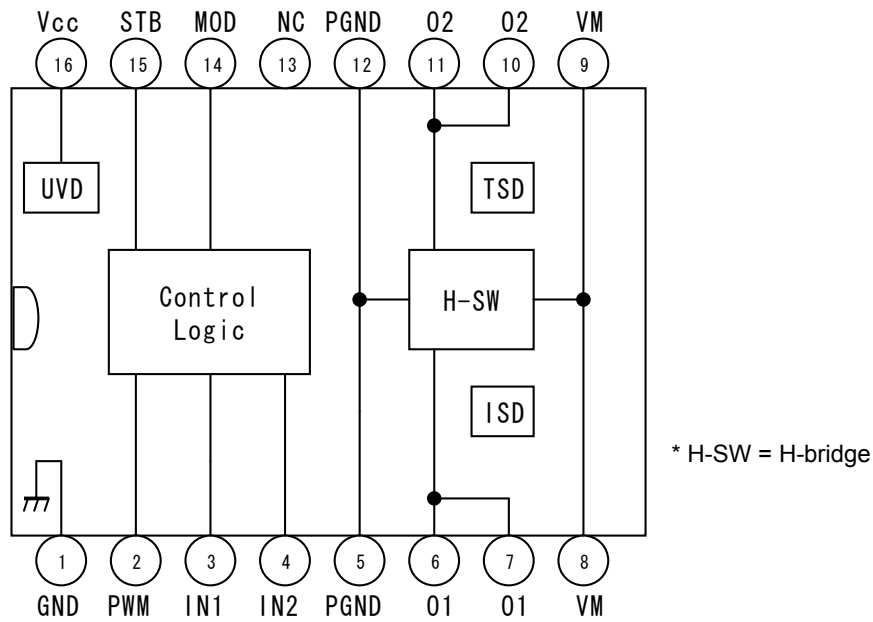

## Pin Functions

No.	Name	I/O	Function	Remarks
1	GND	—	Ground	
2	PWM	I	PWM signal input	200 kΩ pull-down R included
3	IN1		IN1 signal input	
4	IN2		IN2 signal input	
5	PGND	—	Power ground	Motor supply voltage system ground
6	O1	O	Output 1	
7	O1			
8	VM	—	Motor supply voltage	VM = 4.5 V to 45 V
9	VM			
10	O2	O	Output 2	
11	O2			
12	PGND	—	Power ground	Motor supply voltage system ground
13	NC	—	Non connected	
14	MOD	I	Control mode signal input	200 kΩ pull-down R included
15	STB		Stand-by signal input	
16	Vcc	—	Supply voltage	2.7 V to 5.5 V

## Absolute Maximum Ratings (Ta = 25°C)

Characteristics	Symbol	Rating	Unit	Remarks
Supply voltage	VM	50	V	
	Vcc	6		
Input voltage	VIN	-0.2 to 6	V	IN1, IN2, PWM, STB, MOD
Output voltage	Vout	-0.2 to 50	V	O1, O2 pin
Output current	Iout	1.2	A	
	Iout (peak)	2		tw = 20 ms pulse, Duty ≤ 20%
Power dissipation	PD	0.5	W	IC only
		0.78		mounted on PCB Cu ≥ 40%, 50 × 50 t = 1.6(mm)
Operation temperature	Topr	-20 to 85	°C	
Storage temperature	Tstg	-55 to 150	°C	

The Absolute Maximum Ratings of a semiconductor device are a set of ratings that must not be exceeded, even for a moment.

Do not exceed any of these ratings.

Exceeding the rating(s) may cause the device breakdown, damage or deterioration, and may result injury by explosion or combustion.

## Operating Range (Ta = -20°C to 85°C)

Characteristics	Symbol	Min	Typ	Max	Unit
Supply voltage	Vcc	2.7	3	5.5	V
	VM	4.5	24	45	V
Output current	Iout	—	—	1	A
Switching Frequency	fPWM	—	—	350	kHz

For reference ; PD – Ta characteristic

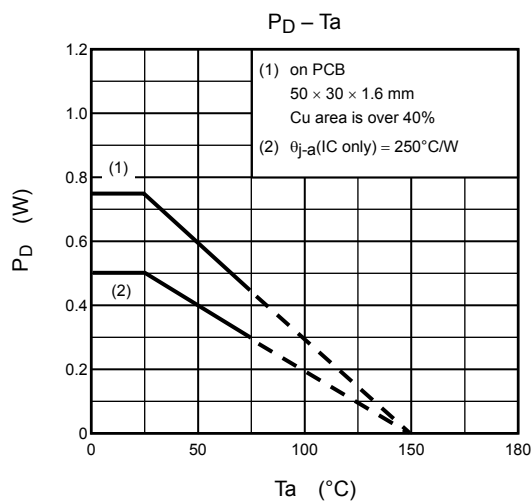

## Electrical Characteristics (unless otherwise specified, Ta = 25°C, Vcc = 3 V, VM = 24 V)

Characteristics		Symbol	Test Condition	Min	Typ.	Max	Unit
Supply current		Icc	STBY = Vcc	—	1.2	1.6	mA
		Icc(STB)	STBY = 0 V	—	—	1	μA
		IM(STB)		—	—	1	
Control input voltage		VIH	—	2	—	Vcc+0.2	V
		VIL		−0.2	—	0.4	
Control input current		IIH	VIN = 3 V	10	15	20	μA
		IIL	VIN = 0 V	—	—	1	
Stand-by input voltage		VIH(STB)	—	2	—	Vcc+0.2	V
		VIL(STB)		−0.2	—	0.4	
Stand-by input current		IIH(STB)	VIN = 3 V	10	15	20	μA
		IIL(STB)	VIN = 0 V	—	—	1	
Output R-on		Ron(U+L)	Io = 1 A, Vcc = VM = 5 V	—	1.4	2	Ω
Output leak current		IL(U)	VM = Vout = 50 V	—	—	1	μA
		IL(L)	VM = 50 V, Vout = 0 V	−1	—	—	
Regenerative diode VF		VF(U)	IF = 1 A	—	1.0	1.1	V
		VF(L)		—	0.9	1	
Low voltage detect voltage		UVLD	Vcc detection (Design target)	—	2.0	—	V
Recovering voltage		UVLC		—	2.2	—	
Over current detection	Detect current	ISDH	Vcc = VM = 5 V (Design target)	—	3.3	—	A
		ISDL		—	4.2	—	
	Response time	ISDM		—	10	—	μs
	Holding time	ISDH		—	10	—	ms
Output start response time		tON(STB)	STBY = L→H (Design target)	—	20	—	μs
Output dead time		tpLH	(Design target)	—	100	—	ns
		tpHL		—	75	—	
Thermal shutdown detect temperature		TSD	(Design target)	—	170	—	°C
Thermal shutdown hysteresis		ΔTSD		—	20	—	

## Input / Output Equivalent Circuit

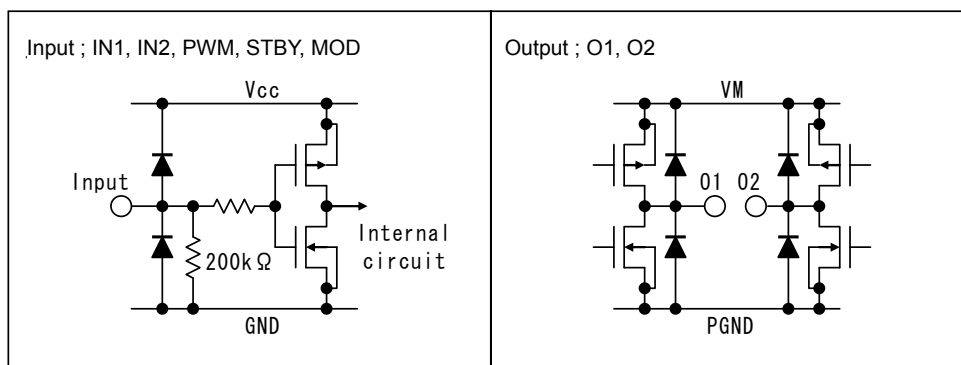

## Truth Value Table (—: don't care)

Input					Output		MODE
IN1	IN2	PWM	MOD	STB	O1	O2	
—	—	—	—	L	OFF	OFF	Standby
L	L	H	L	H	OFF	OFF	Stop
H	L	H	L	H	H	L	CW/CCW
L	H	H	L	H	L	H	CCW/CW
H	H	H	L	H	L	L	Short brake
—	—	L	L	H	L	L	Short brake
H	—	H	H	H	H	L	CW/CCW
L	—	H	H	H	L	H	CCW/CW

H-bridge Function

• To prevent penetrating current, dead time  $t_2$  and  $t_4$  (Typ.=100 ns) is provided in switching to each mode in the IC.

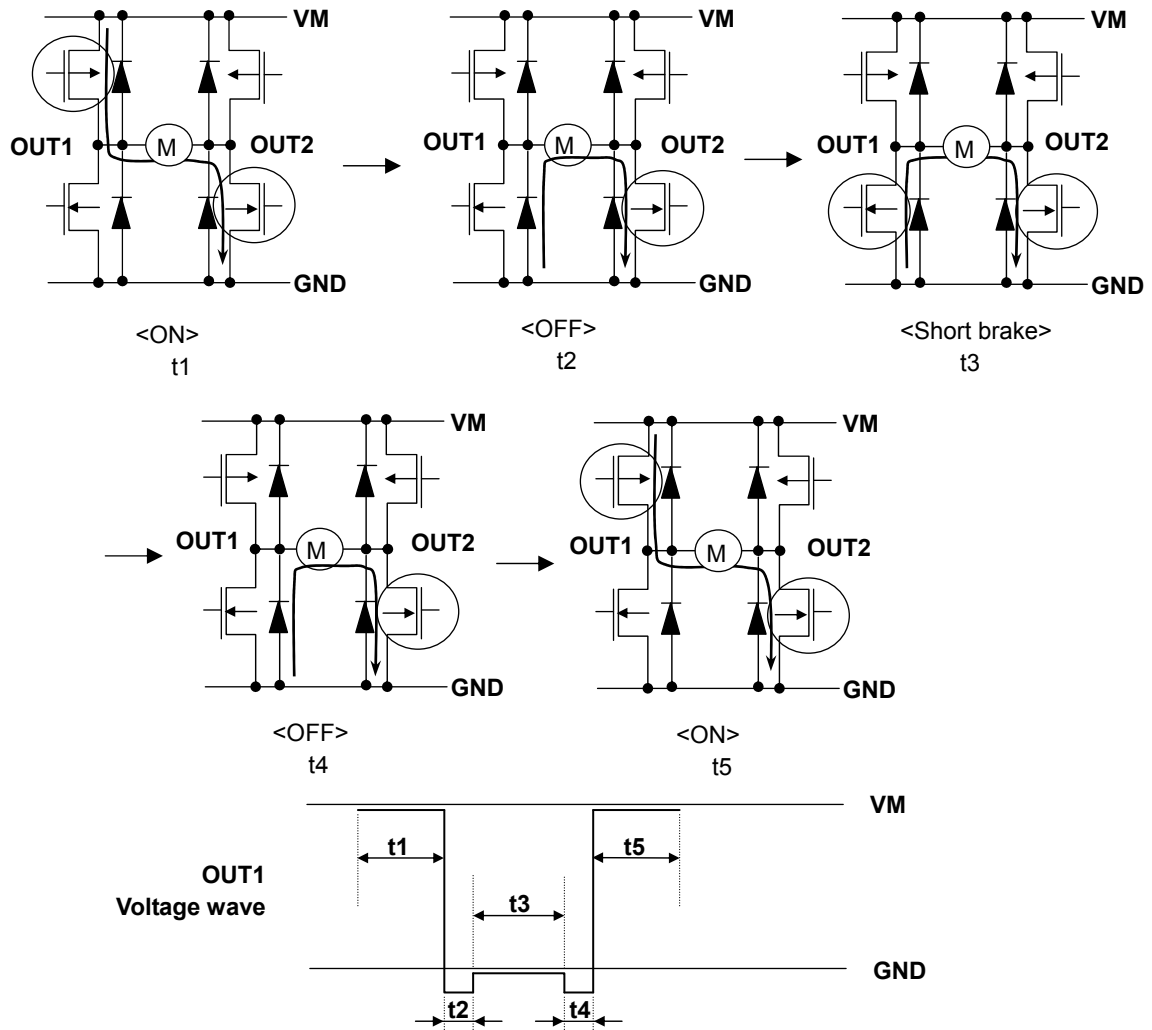

## Application Circuit Example

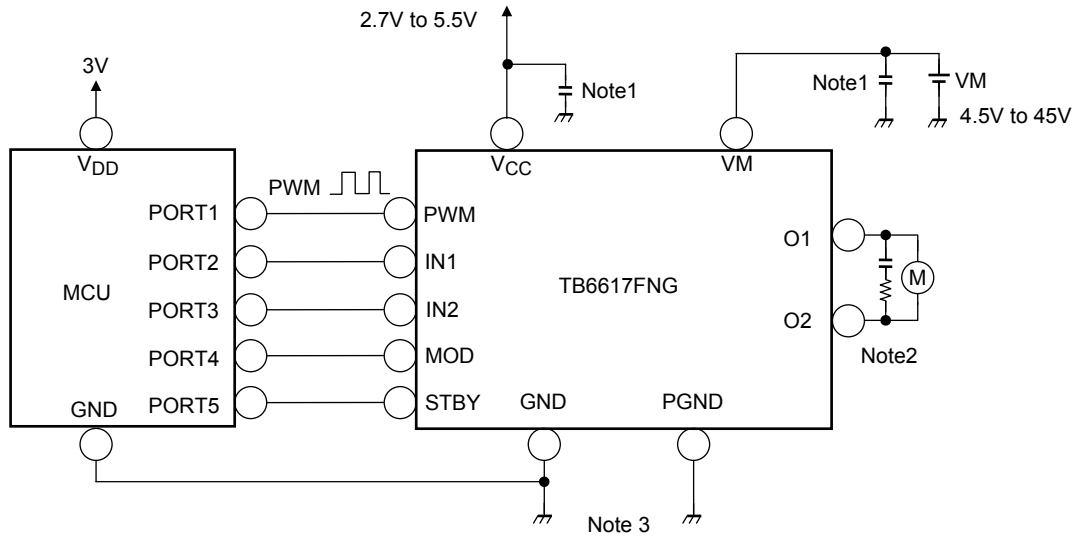

Note1: Capacitors for noise absorption around Vcc or VM system should be connected as close as possible to the IC.

Note 2: Add a resistor for charge current limitation, if use the capacitor between the motor terminals to avoid noise.

Note 3: Avoid common impedance between GND and PGND as possible.

Note 4: Design with extra care for Vcc, VM, GND, PGND lines as there is a possibility of IC destruction from short between output pins, power supply to output pin, ground to output pin, or adjacent pins.

Other: Use fuse or current confine device for the application safety, when current beyond Absolute Maximum Rating would generate through IC.

**Package Dimensions**

SSOP16-P-225-0.65B

Unit : mm

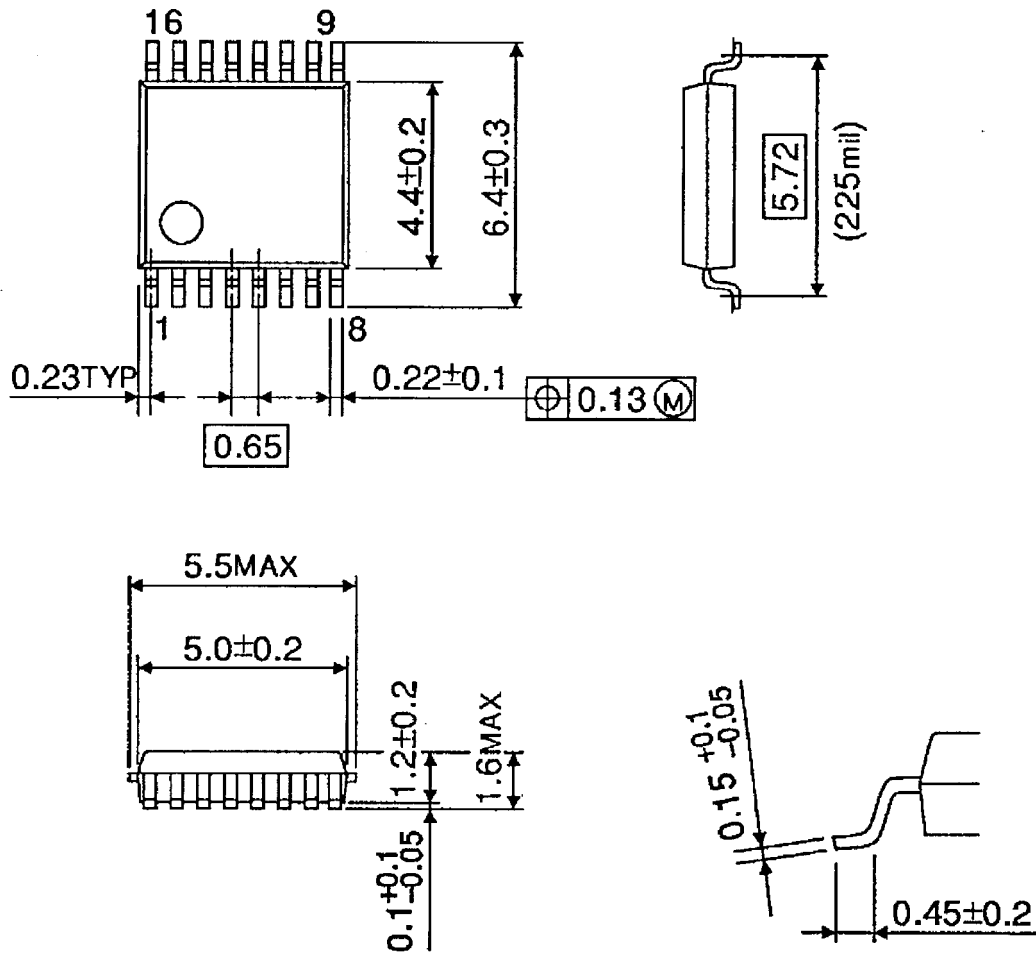

Weight : 0.07 g (typ.)



## Notes on Contents

### 1. Block Diagrams

Some of the functional blocks, circuits, or constants in the block diagram may be omitted or simplified for explanatory purposes.

### 2. Equivalent Circuits

The equivalent circuit diagrams may be simplified or some parts of them may be omitted for explanatory purposes.

### 3. Timing Charts

Timing charts may be simplified for explanatory purposes.

### 4. Application Circuits

The application circuits shown in this document are provided for reference purposes only. Thorough evaluation is required, especially at the mass production design stage.

Toshiba does not grant any license to any industrial property rights by providing these examples of application circuits.

### 5. Test Circuits

Components in the test circuits are used only to obtain and confirm the device characteristics. These components and circuits are not guaranteed to prevent malfunction or failure from occurring in the application equipment.

## IC Usage Considerations

### Notes on handling of ICs

- [1] The absolute maximum ratings of a semiconductor device are a set of ratings that must not be exceeded, even for a moment. Do not exceed any of these ratings.  
Exceeding the rating(s) may cause the device breakdown, damage or deterioration, and may result injury by explosion or combustion.
- [2] Use an appropriate power supply fuse to ensure that a large current does not continuously flow in case of over current and/or IC failure. The IC will fully break down when used under conditions that exceed its absolute maximum ratings, when the wiring is routed improperly or when an abnormal pulse noise occurs from the wiring or load, causing a large current to continuously flow and the breakdown can lead smoke or ignition. To minimize the effects of the flow of a large current in case of breakdown, appropriate settings, such as fuse capacity, fusing time and insertion circuit location, are required.
- [3] If your design includes an inductive load such as a motor coil, incorporate a protection circuit into the design to prevent device malfunction or breakdown caused by the current resulting from the inrush current at power ON or the negative current resulting from the back electromotive force at power OFF. IC breakdown may cause injury, smoke or ignition.  
Use a stable power supply with ICs with built-in protection functions. If the power supply is unstable, the protection function may not operate, causing IC breakdown. IC breakdown may cause injury, smoke or ignition.
- [4] Do not insert devices in the wrong orientation or incorrectly.  
Make sure that the positive and negative terminals of power supplies are connected properly.  
Otherwise, the current or power consumption may exceed the absolute maximum rating, and exceeding the rating(s) may cause the device breakdown, damage or deterioration, and may result injury by explosion or combustion.  
In addition, do not use any device that is applied the current with inserting in the wrong orientation or incorrectly even just one time.

**Points to remember on handling of ICs****(1) Over current Protection Circuit**

Over current protection circuits (referred to as current limiter circuits) do not necessarily protect ICs under all circumstances. If the Over current protection circuits operate against the over current, clear the over current status immediately.

Depending on the method of use and usage conditions, such as exceeding absolute maximum ratings can cause the over current protection circuit to not operate properly or IC breakdown before operation. In addition, depending on the method of use and usage conditions, if over current continues to flow for a long time after operation, the IC may generate heat resulting in breakdown.

**(2) Thermal Shutdown Circuit**

Thermal shutdown circuits do not necessarily protect ICs under all circumstances. If the thermal shutdown circuits operate against the over temperature, clear the heat generation status immediately.

Depending on the method of use and usage conditions, such as exceeding absolute maximum ratings can cause the thermal shutdown circuit to not operate properly or IC breakdown before operation.

**(3) Heat Radiation Design**

In using an IC with large current flow such as power amp, regulator or driver, please design the device so that heat is appropriately radiated, not to exceed the specified junction temperature ( $T_J$ ) at any time and condition. These ICs generate heat even during normal use. An inadequate IC heat radiation design can lead to decrease in IC life, deterioration of IC characteristics or IC breakdown. In addition, please design the device taking into consideration the effect of IC heat radiation with peripheral components.

**(4) Back-EMF**

When a motor rotates in the reverse direction, stops or slows down abruptly, a current flow back to the motor's power supply due to the effect of back-EMF. If the current sink capability of the power supply is small, the device's motor power supply and output pins might be exposed to conditions beyond maximum ratings. To avoid this problem, take the effect of back-EMF into consideration in system design.

## RESTRICTIONS ON PRODUCT USE

- Toshiba Corporation, and its subsidiaries and affiliates (collectively "TOSHIBA"), reserve the right to make changes to the information in this document, and related hardware, software and systems (collectively "Product") without notice.
- This document and any information herein may not be reproduced without prior written permission from TOSHIBA. Even with TOSHIBA's written permission, reproduction is permissible only if reproduction is without alteration/omission.
- Though TOSHIBA works continually to improve Product's quality and reliability, Product can malfunction or fail. Customers are responsible for complying with safety standards and for providing adequate designs and safeguards for their hardware, software and systems which minimize risk and avoid situations in which a malfunction or failure of Product could cause loss of human life, bodily injury or damage to property, including data loss or corruption. Before customers use the Product, create designs including the Product, or incorporate the Product into their own applications, customers must also refer to and comply with (a) the latest versions of all relevant TOSHIBA information, including without limitation, this document, the specifications, the data sheets and application notes for Product and the precautions and conditions set forth in the "TOSHIBA Semiconductor Reliability Handbook" and (b) the instructions for the application with which the Product will be used with or for. Customers are solely responsible for all aspects of their own product design or applications, including but not limited to (a) determining the appropriateness of the use of this Product in such design or applications; (b) evaluating and determining the applicability of any information contained in this document, or in charts, diagrams, programs, algorithms, sample application circuits, or any other referenced documents; and (c) validating all operating parameters for such designs and applications. **TOSHIBA ASSUMES NO LIABILITY FOR CUSTOMERS' PRODUCT DESIGN OR APPLICATIONS.**
- Product is intended for use in general electronics applications (e.g., computers, personal equipment, office equipment, measuring equipment, industrial robots and home electronics appliances) or for specific applications as expressly stated in this document. Product is neither intended nor warranted for use in equipment or systems that require extraordinarily high levels of quality and/or reliability and/or a malfunction or failure of which may cause loss of human life, bodily injury, serious property damage or serious public impact ("Unintended Use"). Unintended Use includes, without limitation, equipment used in nuclear facilities, equipment used in the aerospace industry, medical equipment, equipment used for automobiles, trains, ships and other transportation, traffic signaling equipment, equipment used to control combustions or explosions, safety devices, elevators and escalators, devices related to electric power, and equipment used in finance-related fields. Do not use Product for Unintended Use unless specifically permitted in this document.
- Do not disassemble, analyze, reverse-engineer, alter, modify, translate or copy Product, whether in whole or in part.
- Product shall not be used for or incorporated into any products or systems whose manufacture, use, or sale is prohibited under any applicable laws or regulations.
- The information contained herein is presented only as guidance for Product use. No responsibility is assumed by TOSHIBA for any infringement of patents or any other intellectual property rights of third parties that may result from the use of Product. No license to any intellectual property right is granted by this document, whether express or implied, by estoppel or otherwise.
- **ABSENT A WRITTEN SIGNED AGREEMENT, EXCEPT AS PROVIDED IN THE RELEVANT TERMS AND CONDITIONS OF SALE FOR PRODUCT, AND TO THE MAXIMUM EXTENT ALLOWABLE BY LAW, TOSHIBA (1) ASSUMES NO LIABILITY WHATSOEVER, INCLUDING WITHOUT LIMITATION, INDIRECT, CONSEQUENTIAL, SPECIAL, OR INCIDENTAL DAMAGES OR LOSS, INCLUDING WITHOUT LIMITATION, LOSS OF PROFITS, LOSS OF OPPORTUNITIES, BUSINESS INTERRUPTION AND LOSS OF DATA, AND (2) DISCLAIMS ANY AND ALL EXPRESS OR IMPLIED WARRANTIES AND CONDITIONS RELATED TO SALE, USE OF PRODUCT, OR INFORMATION, INCLUDING WARRANTIES OR CONDITIONS OF MERCHANTABILITY, FITNESS FOR A PARTICULAR PURPOSE, ACCURACY OF INFORMATION, OR NONINFRINGEMENT.**
- Do not use or otherwise make available Product or related software or technology for any military purposes, including without limitation, for the design, development, use, stockpiling or manufacturing of nuclear, chemical, or biological weapons or missile technology products (mass destruction weapons). Product and related software and technology may be controlled under the Japanese Foreign Exchange and Foreign Trade Law and the U.S. Export Administration Regulations. Export and re-export of Product or related software or technology are strictly prohibited except in compliance with all applicable export laws and regulations.
- Please contact your TOSHIBA sales representative for details as to environmental matters such as the RoHS compatibility of Product. Please use Product in compliance with all applicable laws and regulations that regulate the inclusion or use of controlled substances, including without limitation, the EU RoHS Directive. TOSHIBA assumes no liability for damages or losses occurring as a result of noncompliance with applicable laws and regulations.

# Mouser Electronics

Authorized Distributor

Click to View Pricing, Inventory, Delivery & Lifecycle Information:

[Toshiba:](#)

[TB6617FNG\(O,EL\)](#)